

Batteries and Battery Management Systems for Electric Vehicles

M. Brandl,
H. Gall
austriamicrosystems AG
8141 Unterpremstaetten,
Austria

M. Wenger,
V. Lorentz,
M. Giegerich
Fraunhofer IISB: dept.
Power Electronics
Erlangen, Germany

F. Baronti, G. Fantechi,
L. Fanucci, R. Roncella,
R. Saletti, S. Saponara
University of Pisa: dept.
Information Engineering
Pisa, Italy

A. Thaler,
M. Cifrain,
W. Prochazka
Virtual Vehicle Research
and Test Center
Graz, Austria

Abstract—The battery is a fundamental component of electric vehicles, which represent a step forward towards sustainable mobility. Lithium chemistry is now acknowledged as the technology of choice for energy storage in electric vehicles. However, several research points are still open. They include the best choice of the cell materials and the development of electronic circuits and algorithms for a more effective battery utilization. This paper initially reviews the most interesting modeling approaches for predicting the battery performance and discusses the demanding requirements and standards that apply to ICs and systems for battery management. Then, a general and flexible architecture for battery management implementation and the main techniques for state-of-charge estimation and charge balancing are reported. Finally, we describe the design and implementation of an innovative BMS, which incorporates an almost fully-integrated active charge equalizer.

Keywords: *Li-ion batteries, Cell Modeling, Battery Management System, Charge Equalization, State-of-Charge Estimation, Electric Vehicles.*

I. INTRODUCTION

Electric vehicles (EVs) are expected to play an important role in sustainable mobility thanks to the efficient energy utilization and zero-emission when in use. The battery has a great impact on the performance of electric vehicles, basically determining the driving range. As a consequence, the choice of the battery technology and its effective utilization is of paramount importance. From today's perspective, Li-ion chemistry is the battery technology of choice due to its good energy density, good power rating and charge/discharge efficiency in pulsed energy flow systems. Usually, a large number of cells, depending on the application, are series-connected to build a battery string with the required voltage (up to 400 V).

Li-ion chemistry is very sensitive to overcharge and deep discharge, which may damage the battery, shortening its lifetime, and even causing hazardous situations. This requires the adoption of a proper Battery Management System (BMS) to maintain each cell of the battery within its safe and reliable operating range. In addition to the primary function of battery protection, a BMS should estimate the battery status in order to predict the actual amount of energy that can still be delivered to

the load. This is quite a challenging task, as the performance of the battery in terms of usable capacity and internal resistance, varies over time.

Another important function of a BMS is to extend the battery life by facing the charge unbalancing issue that may arise in series-connected cells. This reduces the usable capacity of the battery because the least charged cell determines the end of discharge, even if there is still energy stored in the other cells of the battery. Due to the strict voltage limits applying to Li-ion batteries, charge unbalancing cannot be self-recovered, but instead worsens with time. Indeed, when one cell reaches the upper voltage limit, the charging process must be interrupted causing some cells not to be fully recharged. Even assuming that all the cells have the same capacity (capacity mismatch is typically limited to only a few percent), charge unbalancing can be caused by cells with different self-discharge rates. This mismatch can also be determined by a temperature gradient along the battery string. A BMS should thus implement a charge equalization technique to periodically restore the balanced condition.

The purpose of this paper is to describe the main issues in the design and management of a battery for an electric vehicle. The paper covers aspects ranging from Li-ion technology (Section II) to BMS requirements (Section III) and architectures and techniques for battery status estimation and charge equalization (Section IV). They are then applied to the design of an innovative BMS to be integrated in an electric vehicle (Section V). The implemented BMS includes the first almost fully-integrated active charge equalizer. Conclusions are drawn in Section VI.

II. LITHIUM BATTERY TECHNOLOGY AND MODELING

A. Challenges in Modeling a Cell

In contrast to several other electro-chemical (EC) systems, the Li-ion battery allows a variation of combinations of different cell materials. Different anode and cathode materials combined with different separators and electrolytes result in a huge challenge in cell and system design. Any change of a single component modifies the cell characteristics. A lot of effort is necessary to obtain valuable testing results, especially

when it comes to lifetime aspects. This effort has great potential to be reduced by improving the modeling of these systems.

B. Different Modeling Approaches

The first approach comes from looking at an electro-chemical system from outside (*Black-Box Approach*). The voltage-current characteristics are used to extract the parameters of the mathematical functions that describe an electro-chemical system. This results in fast computation models. Usually, these models do not allow direct variations of the parameters following a system change (e.g. different separator thickness) without repeating all the measurements needed for parameterizing the model. A second approach is the electrical lumped-model. This kind of modeling allows fast results in calculation. On the other hand, there are several drawbacks when the coverage of the broad operation region in an automotive application is required. Tackling the parameter variation with temperature, state-of-charge, current density and lifetime requires indeed very complex look-up tables to fit the characteristics of the model into those of the cells.

The third approach is to model the electro-chemical system itself. In the following, a model is derived from detailed physical and chemical characteristics. This model also covers charge and discharge effects reflecting real life system behaviors of Li-ion systems. The main aspects are:

- Electronic conductivity in current collectors and electrode materials,
- Solid-state-diffusion of lithium inside the highly porous electrodes,
- Charge transfer, SEI (Solid-Electrolyte Interphase)-transfer and solvation of lithium ions,
- Lithium diffusion in electrolyte,
- Ohmic and kinetic heat generation,
- Neutral charge and energy balance.

These phenomena are described by nonlinear, coupled differential equations. A high number of parameters is needed and the results of predicted application cases are not robust enough and must be enhanced. Different parameters are estimated the long way round because they are not directly available through measurements. Furthermore, evaluated parameters are only representative for a single electrochemical system, if not a single cell from a single supplier. These parameters are also influenced by the production process and the quality of the production line.

End-of-life criteria depend on the application considered. Usually, a predefined number of load cycles is required over the lifetime. Life limiting characteristics are the reduction of the capacity and the increase of the internal resistance of the cell. These two characteristics directly affect driving range and available power respectively. On the one hand, capacity loss is directly influenced by the deactivation of active material (real capacity loss) and, on the other hand, by an increase of the internal resistance. In the latter case, the capacity is still available, but cannot be fully utilized under real load

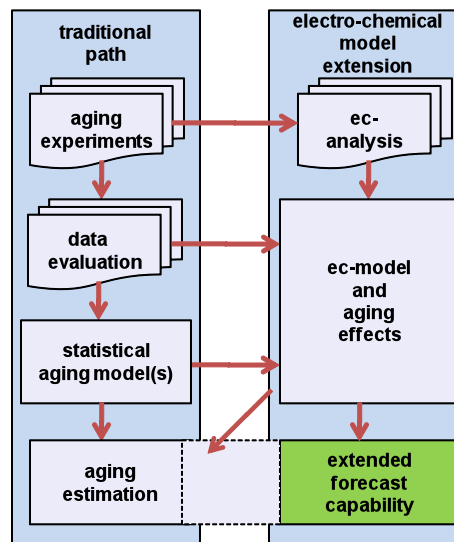

Figure 1. Aging forecast with electro-chemical model extension

conditions. The physical-chemical modeling approach is the most effective when applied to different cell geometries to predict cell lifetime. This approach is based on deterioration mechanisms and the related change in material and cell parameters. On the other hand, the evaluation of this parameter set requires a lot of time and specialized measurement equipment, as a typical target for a battery in field is usually 10 years or higher.

C. EC-modeling and aging

From an application perspective, the mechanistic modeling of aging aspects of a Li-ion system is a huge challenge. In addition to the effort on parameterizing such models, the calculation time is outside the time scale of a battery system developing cycle. A tool useable in industry should produce results quickly. Aging of Li-ion battery systems is described with statistical models today. The data input of these models must be gathered during long testing periods. That procedure requires that test matrix is well defined. If requirements on the final product vary in the development phase, covering these new requirements with the previously defined test matrix is pure luck. Changing the test matrix during the test procedure itself is jeopardizing any time schedule.

D. Why not combining statistical models and EC-models when it comes to aging prediction?

The knowledge of which parameters and how they affect aging is a critical issue, when defining a Design-of-Experiments based test matrix. Understanding the aging behavior even in single aspects helps to design more reliable test setups. In today's early product development phase of Li-ion battery systems, we need to take into account changing key parameters. What to do, when major key factors influencing life performance (e.g. thickness of active material coated on the current collector foil) must be changed? A new test set up requires time and seriously postpones the development schedule of a product. A combination of statistical models and an EC extension is a way to get hands on more reliable aging

prediction. Figure 1 shows the possible influence of an EC-model aligned to aging effects, when aging prediction of electrochemical systems is considered.

III. REQUIREMENTS AND STANDARDS FOR BATTERY MONITORING AND MANAGEMENT

Battery management is mandatory for Li-ion batteries to ensure energy availability, lifetime and safety of the energy storage system. Battery current, voltage and temperature over time are the major inputs of an electronic battery management system. This is in charge of battery protection and state-of-charge (SoC), state-of-health (SoH) and state-of-function (SoF) estimation. Additional tasks are controlling the heating/cooling subsystem and the main power switch, ensuring the isolation of the high voltage from the vehicle, implementing isolated communication with the in-vehicle network.

From an electronic point of view, challenges are the accurate and synchronous measurement of the battery current and the voltage of the pack cells, along with data communication over a number of voltage domains and fulfillment of ASIL-C safety requirements. Typical accuracy targets are 0.5-1 % for currents up to 450 A and 1-2 mV and 0.1 % for voltages at cell and pack level respectively. This stringent demand for voltage accuracy is mainly driven by LiFePO₄ chemistry. This is one of the preferred technology for automotive applications, as it features a good compromise among energy density, costs, safety properties, lifetime and cycle resistance. A very flat characteristic for the open circuit voltage versus state-of-charge stands for this battery technology. This makes accurate state of charge estimation from voltage measurement very difficult, especially in the 20% to 80% state-of-charge range. Other automotive Li-ion chemistries, like Li-Titanate (which has even better cycle resistance, fast charge properties but lower energy density) or Li-Mangan, are less demanding in terms of voltage measurement accuracy than LiFePO₄ cells. From a semiconductor component point of view, it is essential to design for integrated error compensation techniques and accordingly to the ISO26262 design flow. In addition, having high precision production test equipment in place and going for comprehensive product qualification is required for an accurate assessment of the product parameters.

Assuming a linear and offset free measurement system, the main error sources in shunt current measurement are the variation of shunt resistance, amplifier gain and ADC reference over temperature and time. The error sources in voltage measurement are ADC reference variation over temperature and time, common mode voltage variation along the battery string and the tolerances affecting the resistive voltage divider. In battery management systems, no re-calibration is foreseen and full accuracy must be maintained for all the vehicle life. However, there are physical reasons for long term drift of the measurement system. Most significant ones are related to threshold shift of MOS transistors when biased, mechanical stresses that may induce MOS parameter shift and long-term relaxation effects. Comprehensive qualification tests with the help of highly accurate automatic test equipment resources provide the basis for good accuracy predictions over lifetime. Pre-aging of the electronics in biased high temperature

operating environment needs to be considered to minimize long term accuracy degradation and to achieve the highest accuracy.

IV. TECHNIQUES FOR BATTERY MANAGEMENT, CHARGE EQUALIZATION AND SOC ESTIMATION

Architectural choices for implementing a battery management system can be driven by the physical structure of the battery used in the targeted application. In high power applications, around ten to over one hundred of high-capacity elementary cells are series-connected to build up the required battery voltage. The overall cell string is usually segmented into modules consisting of 4 to 14 series-connected cells. Thus, the battery can be seen as made of three nested layers: namely the elementary cell, the module, and the pack (i.e. the series of modules). Each layer can serve as an intelligent platform for the effective implementation of a subset of the BMS monitoring and management functions. This approach leads to the BMS hierarchical architecture schematically depicted in Figure 2. The most inner layer hosts the Cell Monitoring Unit (CMU), one for each cell of the string. The middle layer consists of the Module Management Units (MMUs), one for each module in which the string has been partitioned. The MMU uses the basic monitoring functions implemented by the inner CMUs and provides higher-level services to the Pack Management Unit (PMU), which supervises all the battery string. A dedicated and custom bus can be used to connect each CMU to the relevant MMU. A shared galvanic-isolated Controller Area Network (CAN) bus is instead the preferred choice to implement the communication between the MMUs and the PMU. The latter embeds also the interface between the battery and the other control systems of the targeted application. In an electric vehicle, the PMU is linked to the Vehicle Management System (VMS) through the external CAN bus, as shown in Figure 2, or other higher speed fault-

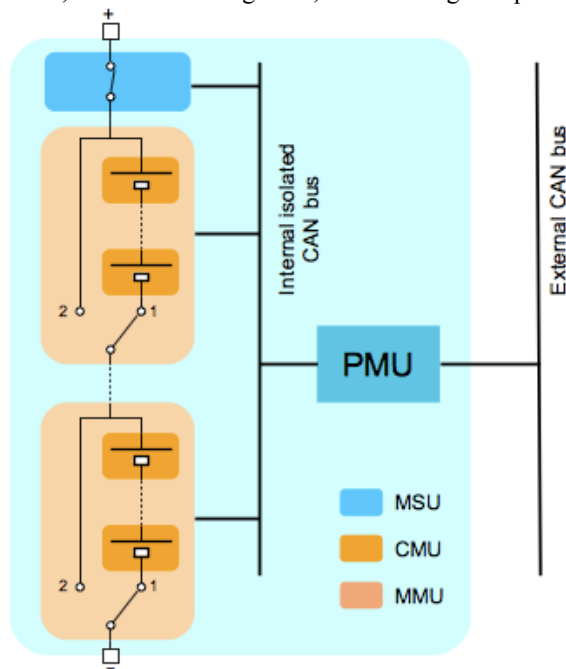

Figure 2. Hierarchical architecture of the BMS showing the Cell Monitoring Unit (CMU), the Module Management Unit (MMU) and the Pack Management Unit (PMU). MSU is the Main Switch Unit.

TABLE I. COMPARISON OF DIFFERENT BALANCING TECHNIQUES

	Technique	Pros	Cons
PASSIVE	<i>Cell-to-Heat</i> (One bleeding resistor and switch per cell)	<ul style="list-style-type: none"> • Very simple • Very cheap 	<ul style="list-style-type: none"> • 0% efficiency • Slow
	<i>Module-to-Cell</i> (Charge transfer from a battery module to a single cell by means of a galvanic isolated DC/DC converter)	<ul style="list-style-type: none"> • Relatively simple • Good efficiency • Fast 	<ul style="list-style-type: none"> • Switch network • High isolation voltage of the DC/DC
ACTIVE	<i>Distributed</i> (Charge transfer from adjacent cells)	<ul style="list-style-type: none"> • Moderate efficiency • Moderately fast 	<ul style="list-style-type: none"> • Bulky • Complex control
	<i>Cell-to-Cell</i> <i>Shared</i> (Charge transfer from cell A to tank, then from tank to cell B)	<ul style="list-style-type: none"> • High efficiency • Fast 	<ul style="list-style-type: none"> • Switch network
	<i>Cell/Module Bypass</i> (A cell/module disconnection from the current path)	<ul style="list-style-type: none"> • High balancing efficiency • Very fast and flexible 	<ul style="list-style-type: none"> • High current switches • Complex to implement • Decrease battery efficiency during normal operation

tolerant busses, like the FlexRay one [1].

The above described hierarchical architecture platform is very flexible, as the BMS functions can freely be distributed and – if redundancy is needed – replicated over all the three layers of the platform. An instance of the hierarchical platform is presented in the next section. That instance exploits only the two outer layers of the platform, as the designed BMS embeds a MMU for each battery module and a PMU. This is a common choice, mainly driven by the fact that providing each cell with a dedicated CMU can be relatively expensive and can increase the overall self-discharge rate of the battery in a non-negligible way. However, the current trend is to build up the battery by series-connecting very high-capacity cells, instead of groups of parallel-connected cells with smaller capacity. This way the cost and power consumption of the CMU may become affordable, if compared to the cost (roughly 400 €/kWh) and self-discharge rate (typical value is 3 % a month) of a very high capacity cell. The use of the cell layer can bring some advantages in implementing the BMS monitoring tasks. In fact, the CMU can easily act as a gauge measuring the voltage and the temperature of the related cell. This provides the basic support for adding redundancy to this key BMS function in an effective way. In addition, as the CMU can be embedded in the cell case, it allows some valuable information, such as the serial number, the lifetime, the number of cycles to be evaluated and stored into the cell itself. This enables an easy tracking of the cell history and the potential use in a second market application, like smart grid [2], when the progressive degradation of the usable capacity of the cell makes it no longer suitable for an electric vehicle.

Battery protection against overcharge, deep discharge and over-temperature is usually achieved breaking the battery current flow through the Main Switch Unit (MSU) contactor. This method can be combined with the possibility of excluding a segment of the string from the current path by the two-way switch present in each module (see Figure 2). This way the cells of the bypassed segment are being protected, while the battery is still capable of delivering power to the load. Furthermore, the insertion of the two-way switches enables the dynamic reconfiguration of the string.

This mechanism also provides a direct method for charge equalization. Indeed if a segment reaches the full charge, it can be disconnected from the current path, so that the charging of the remainder cells of the string can continue. Depending on the switch granularity, this method can be applied to a string segment made up of a single cell [3], allowing charge balancing at cell level. However, this approach requires a pair of bidirectional switches for each cell of the battery and it can be impracticable in high power applications due to the related complexity and cost and to the loss of efficiency during normal battery operation. Thus, this method seems to be more attractive if applied to the segment level instead of the cell one. This is because only one high-current two-way switch is needed per each module.

Different approaches have been proposed for charge equalization. A good review of different balancing techniques is provided by [4]. A comparison is shown in Table I, where the above described method is reported as *Cell/Module Bypass*. It falls in the category of active balancing techniques. The extra energy stored in the more charged cells is not dissipated as heat through a bleeding resistor, as it happens in passive equalization, but instead is transferred to the less charged cells. Different active balancing techniques are possible depending on the way the energy is redistributed among the cells. However, a really good trade-off between circuit complexity of the active balancing method and achievable efficiency has to be found to make active balancing competitive against passive equalization. Passive balancing implementation is really straightforward, because it requires just one controlled switch and resistor per cell. The most promising approaches seem to be the *Module-to-Cell* and the *Shared Cell-to-Cell* techniques [5], in which a single DC/DC converter is used to equalize the charge among the cells of a module. In fact, a single converter can be designed with a very high efficiency and also the number of the bulky passive components (inductors and capacitors) is minimized when compared to the *Distributed Cell-to-Cell* technique. An interesting implementation of the *Module-to-Cell* employing a flyback DC/DC converter is reported in the next section.

The hardware implementation of the charge equalizer

circuit lies in the MMU, while the overall balancing procedure is usually supervised by the PMU, which controls the amount of charge stored in each cell of the string. To do this, the PMU needs to estimate the state-of-charge of each cell of the battery string, that is, the charge present in the cell divided by its nominal capacity. The latter corresponds to the amount of charge that can be stored in the cell when it is fully charged. As stated above, this is true only at the beginning of the battery life, as the actual cell capacity gradually decreases with time. Thus, an accurate modeling of the aging effect is very important for a precise estimation of the remaining charge stored in a cell.

Assuming that the initial value is known, SoC can be evaluated by integrating the battery current over time. This method is called Coulomb counting and is commonly used in low power applications, as portable consumer devices. However, Coulomb counting is very sensitive to measurement errors, particularly those caused by offset temperature drifting of the current sensor, which may lead to large SoC errors over time, because of the current integration. Another simple method to estimate the state-of-charge is to make use of the relationship between SoC and open circuit voltage (OCV). However, OCV dependence on SoC in Li-ion batteries is very small, so the measurement of OCV must be very accurate. This requires the battery being in steady state, a condition that is reached only after a long time (often several minutes or even hours) with no load connected. Thus, this approach is unsuitable for real-time SoC estimation in electric vehicles, where the battery is continuously charged or discharged with high currents.

Among other methods reported in the literature [6], such as discharge tests, internal resistance measurement, or neural networks, model-based algorithms (such as Kalman filters [7] or mix algorithms [8]) seem to be the most attractive for online SoC estimation in EVs. This is because they use onboard noisy voltage and current measurements and they do not require long tuning times as artificial neural networks do. However, model-based methods require an accurate modeling of the cell behavior for all the cell lifetime and in all the operating conditions. This implies that temperature effects on the cell behavior must also be taken into account [9].

V. BATTERY INTEGRATION IN ELECTRIC VEHICLES

The way a battery system is integrated into an electric vehicle depends on many different aspects. Therefore, a rule applicable to all possible integration cases cannot be stated. Instead, an example will be given to show the most relevant aspects. The example is derived from the experience gained in the E³Car project [10]. The battery system uses 96 series-connected Li-ion cells with 50 Ah capacity in order to reach the required voltage level of up to 400 V. The cells are divided into modules of four cells. The battery pack consists of 24 modules each of them including an electronic circuit for monitoring and balancing the cells, which has been designed according to the requirements outlined in Section III.

Figure 3 shows such a battery system. The concept is based on the architecture described in Section IV. Besides the battery modules with the module management unit, the battery system

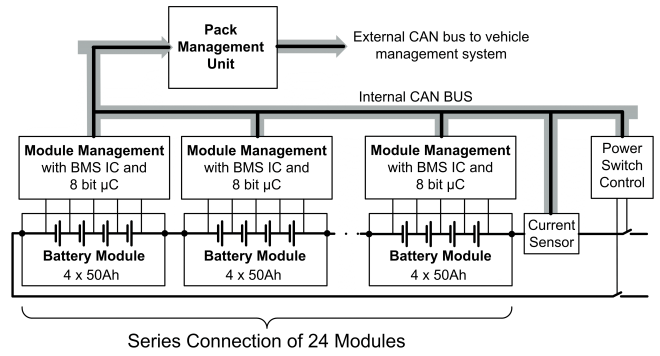

Figure 3. Battery system overview

includes the pack management unit. Its role is to acquire data from the module management units and the current sensor, calculate the battery parameters, such as state of charge, state-of-health and state of function, communicate with the vehicle control system, operate the power switches and control the battery cooling and heating subsystems. The battery module management units and the pack management unit communicate via a CAN bus. As the MMUs are monitoring voltages at levels up to about 400 V, it is necessary to provide a galvanic isolation of the communication lines and the power supply of the monitoring circuits from the rest of the vehicle. Figure 4 shows a concept of galvanic isolation where every component is on its own potential, whereas the CAN bus is referenced to the vehicle chassis ground.

A. Battery Monitoring

Figure 5 gives a more detailed overview of the module and its monitoring circuit. The core of the monitoring circuit is the battery monitoring IC. In this case the newly developed AS8505 by austriamicrosystems was used. It is the first IC that features an integrated active cell balancing method, which has been described as *Module-to-Cell* method in Section IV. This monitoring IC directly communicates with a microcontroller via SPI bus and various digital I/O lines. The role of the microcontroller is to enable the communication between the monitoring IC and the PMU via CAN bus, control cell data acquisition and monitor the balancing process. Therefore, it is sufficient to use an 8-bit microcontroller, an ATMEL AT90CAN128 in this case. The functions demanding more

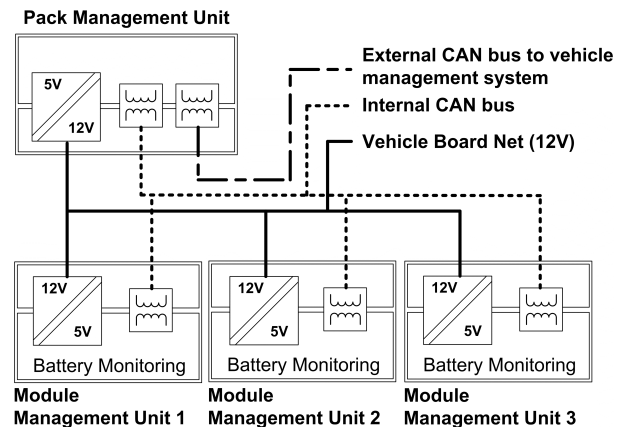

Figure 4. Galvanic isolation concept

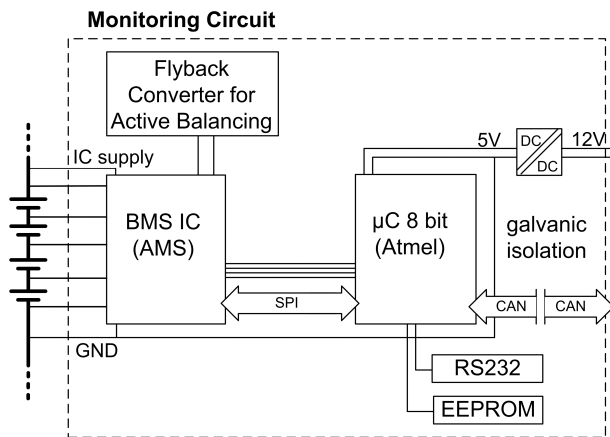

Figure 5. Battery Monitoring and balancing circuit overview

calculation power (e.g. SoC, SoH and SoF) are implemented on the PMU board, which uses a 32-bit Infineon TriCore TC1797 microcontroller. The PMU gathers information from all the MMUs and the current sensor in order to generate a precise estimation of the battery status. A demonstrator consisting of module and pack management units is shown in Figure 6. The battery management circuit can be seen in the front, whereas two modules with their monitoring circuit are visible in the back.

B. Measurements

Cell voltage measurements showing the active balancing function are shown in Figure 7. Cell 1 has a slightly higher voltage level than the other cells at the beginning of the acquisition. The cells with lower voltage are receiving charge pulses, thus the cell voltages are being equalized over time. This is a rather slow process. For demonstration purpose very small cells of about 100 mAh were used to show the effect of active balancing. In an electric vehicle application, the balancing action can be done while the vehicle is not used for driving, e.g. during the night. It is thus possible to maintain a balanced battery stack, even with a relatively low balancing current, which is a pre-requisite for single chip integration.

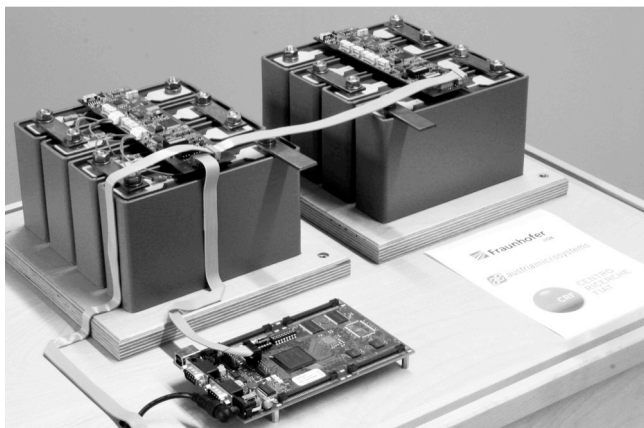

Figure 6. Photograph of the pack management circuit (front) and of 2 battery modules (back)

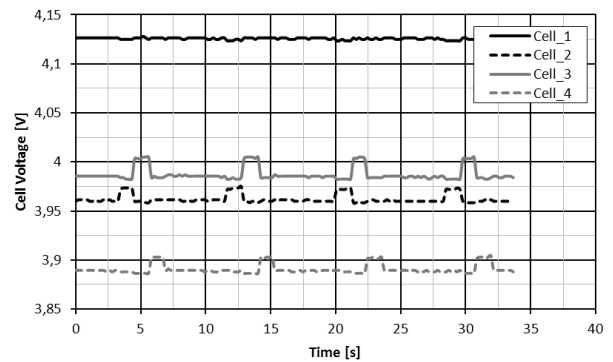

Figure 7. Diagram showing the cell balancing procedure

VI. CONCLUSIONS

The main issues in the design and management of a battery for an electric vehicle have been presented. After the definition of a flexible hierarchical platform for BMS implementation and an overview on the main techniques for charge balancing and state of charge estimation, we have described the design and experimental validation of an innovative BMS for an electric vehicle. The main approaches for cell modeling comprising of an effective solution to predicting cell lifetime have also been discussed.

ACKNOWLEDGMENT

This work was partially supported by the ARTEMIS Joint Undertaking under Project “Pollux (Process Oriented eElectrical control Units for Electric Vehicles Developed on a Multi-System Real-Time Embedded Platform)” and by the ENIAC Joint Undertaking under Project E³Car.

REFERENCES

- [1] F. Baronti et al., “Design and Verification of Hardware Building Blocks for High-Speed and Fault-Tolerant In-Vehicle Networks,” *IEEE Trans. Ind. Electr.*, vol. 58, no. 3, pp. 792–801, Mar. 2011.
- [2] P. Wolfs, “An economic assessment of “second use” lithium-ion batteries for grid support,” in *Proc. 20th Australasian Universities Power Engineering Conference (AUPEC)*, Dec. 2010, pp. 1–6.
- [3] A. Manenti, et al., “A new BMS architecture based on cell redundancy,” *IEEE Trans. Ind. Electron.*, vol. 58, no. 9, pp. 4314–4322, 2011.
- [4] J. Cao, N. Schofield, and A. Emadi, “Battery balancing methods: A comprehensive review,” in *Proc. IEEE Conf. Vehicle Power and Propulsion*, 2008, pp. 1–6.
- [5] F. Baronti, et al., “Hierarchical platform for monitoring, managing and charge balancing of LiPo batteries,” in *Proc. Vehicle Power and Propulsion Conf.*, Sep. 2011, pp. 1–6.
- [6] S. Piller, M. Perrin, and A. Jossen, “Methods for state-of-charge determination and their applications,” *Journal of Power Sources*, vol. 96, no. 1, pp. 113–120, 2001.
- [7] H. He, et al., “State-of-charge estimation of lithium-ion battery using an adaptive extended kalman filter based on an improved thevenin model,” *IEEE Trans. Veh. Technol.*, vol. 60, no. 4, pp. 1461–1469, May 2011.
- [8] F. Codeca, S. Savaresi, and G. Rizzoni, “On battery state of charge estimation: A new mixed algorithm,” in *Proc. IEEE Int’l Conf. on Control Applications*, Sep. 2008, pp. 102–107.
- [9] F. Baronti, et al., “State-of-Charge Estimation Enhancing of Lithium batteries through a Temperature-Dependent Cell Model,” in *Proc. IEEE Applied Electronics*, Sep. 2011, pp. 1–5.
- [10] ENIAC Joint Undertaking “E³Car Project,” [Online] www.e3car.eu