

Fuzzy-logic digital-analogue interfaces for accurate mixed-signal simulation

Tom J. Kazmierski, University of Southampton, tjk@ecs.soton.ac.uk

Abstract

A new approach to mixed-signal circuit interfacing based on fuzzy logic models is presented. Due to their continuous rather than discrete character, fuzzy logic models offer a significant improvement compared with the classical D-A interface models. Fuzzy logic D-A interfaces can represent the boundary between the digital and analogue worlds accurately without a significant loss of computational efficiency. The potential of mixed-signal interfacing based on fuzzy logic is demonstrated by an example of spike propagation from the digital to analogue world. A model of inertial propagation delay and non-linear DC gain suitable for fuzzy logic gates is also suggested.

1. Introduction

The main characteristic of the fuzzy logic is the use of continuous, rather than discrete, waveforms. The advantages of using fuzzy logic for mixed-signal circuit interfacing become evident in situations where the crude propagation delay models do not show spikes or glitches. Events that generate spikes are sometimes cancelled in classical logic analysis whereas in mixed-signal simulations it would be more appropriate to propagate spikes into the analogue part of the circuit. Basic fuzzy logic operations for circuit analysis (such as NOT, AND, OR) can be derived directly from the set operations proposed by Zadeh [1] and others [2,3,4]. In the modelling of classical digital-to-analogue interfaces it is usually assumed that, for each logic drive to the analogue part of the interface, the corresponding analogue output model switches between two analogue voltages; one for the driver's low output state and the other for its high output state. The switching timing is determined by external (logic) signals to the interface's digital drivers [5]. Models of this type can satisfactorily reflect the effects of digital event cancellations but cannot simulate the propagation of residual voltage spikes into the analogue domain. The fuzzy-logic digital-to-analogue interface model described here simulates logic events as smooth waveforms and can

therefore show small glitches caused by hazards. Continuous fuzzy-logic waveforms lend themselves easily to analogue interfacing and are very well suited for mixed-signal simulations. Fuzzy-logic models have already been applied in behavioural VHDL simulations [6,7]. Also, system-level behavioural modelling techniques for generic analogue-digital blocks, which have recently been developed [8,9], can benefit from the continuous digital approach offered by fuzzy logic.

2. Fuzzy-signal circuit simulation

Circuit simulation based on fuzzy logic is an alternative to the more usual Boolean-logic analysis. Fuzzy operations in logic gates can be defined as [1]:

Fuzzy logic	Boolean logic
$1 - A$	not A
$\min(A,B)$	A and B
$\max(A,B)$	A or B

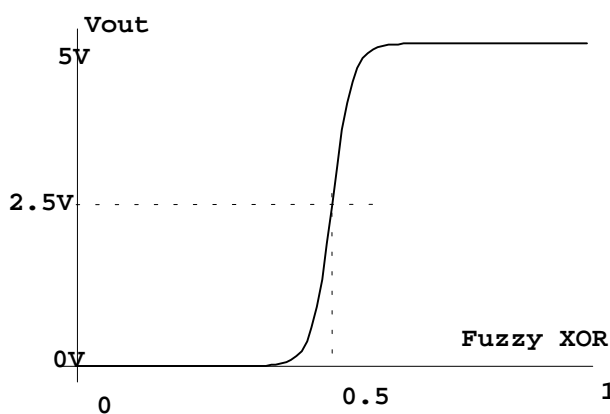

Figure 1. A fuzzy-to-analogue interface.

A sample mapping of fuzzy logic into the analogue domain is shown in Fig. 1. Propagation delays in fuzzy logic gates can be modelled by linear first-order integration and a non-linear DC transfer function. The block diagram in Fig.2 shows a model of the delay inertia and gain which is an approximation of the gate's physical properties.

The suggested inertial delay model is a first-order linear differential equation of the form

$$\tau \frac{dV_d(t)}{dt} + V_d = V_{in} \quad (1)$$

where: V_{in} is the fuzzy input waveform, V_d is the delayed fuzzy output and τ is the time constant.

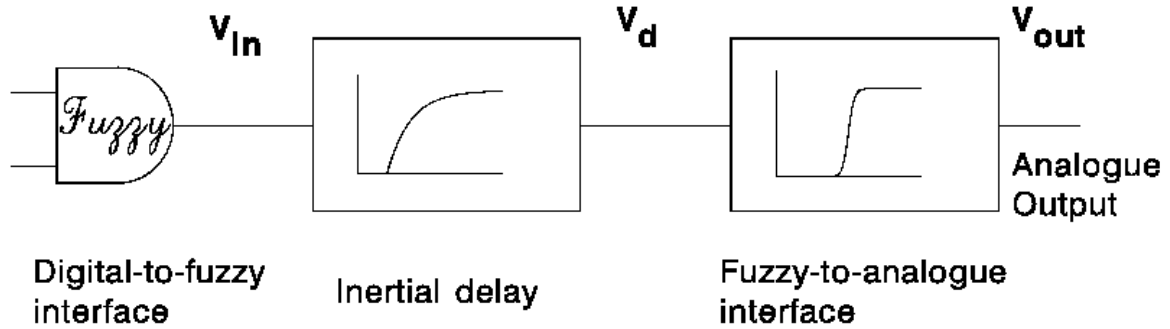

Figure 2. A fuzzy-to-analogue interface with inertial delay.

In a march-in-time simulation with arbitrary input signals V_{in} , the analytic solution of Eqn. 1 is not generally known and V_d must be found by means of some numerical discretization scheme such as the Backward Euler formula:

$$\frac{dv(t_{n+1})}{dt} \approx \frac{v(t_{n+1}) - v(t_n)}{h} \quad (2)$$

where $h = t_{n+1} - t_n$ is the simulation step size. Thus, the integrated output signal V_d at the time-point t_{n+1} can be calculated as

$$V_{d,n+1} = \frac{hV_{in,n+1} + \tau V_{d,n}}{\tau + h} \quad (3)$$

where $V_{d,n+1}$ is the new output value and $V_{d,n}$ is the previous output. The propagation delay shown in Fig.3 is a direct result of both the integration and non-linear transfer characteristic. When the input signal changes its logic value, the change observed on the output is delayed. Assuming that the logic threshold in the non-linear transfer characteristic is equal to 0.5, the propagation delay d can be estimated as $d = \ln 2\tau \approx 0.69\tau$.

When the integrated waveform $V_d(t)$ exceeds the gate's logic threshold the output $V_{out}(t)$ begins to change as illustrated in Fig. 3. This model is more accurate than the standard binary-logic model of inertial delay and it corresponds more closely to the performance of real logic gates.

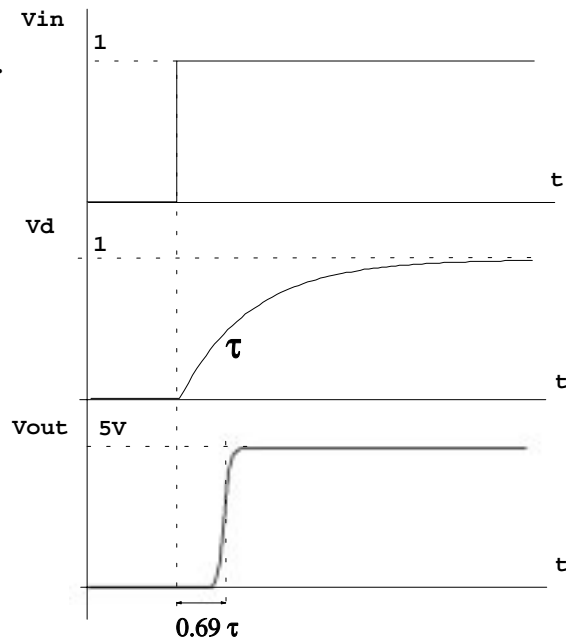

Figure 3. Fuzzy gate propagation delay.

3. Spike propagation in fuzzy-logic interfaces

Very short spikes, which are unlikely to exceed logic thresholds, are often cancelled in binary logic simulation. This could be justified in purely logic simulations because short spikes do not propagate through gates and have no effect on binary logic behaviour. However, in mixed-signal circuit analysis, it is erroneous to neglect cancelled events that can give rise to spikes propagating to the analogue domain.. A test simulation of a fuzzy XOR gate with an analogue RC filter on its output was carried out. The gate was driven by two identical square-wave waveforms but shifted in phase by 5ns such that the XOR function produced short spikes on each edge of the waveform. The results are shown in Fig. 4.

Two points can be made about the effects of spike propagation in this example. Firstly, even spikes, that are shorter than the gate propagation delay, have

a visible effect on the analogue side of the circuit. Secondly, the gate internal state changes when the gate is driven by the fast waveform, and consequently affects the amplitude of spikes. This effect is present in the results and it might not be detected by a mixed-signal simulator using standard Boolean-logic digital-analogue interface models..

4. Conclusion

Fuzzy logic interfaces offer potential to represent the boundary between the digital and analogue worlds accurately. It was found that a fuzzy-logic model of the interface can satisfactorily be used to solve the problem of spike cancellation on the boundary. Other numerical problems of mixed-signal interfacing, such as rapid analogue signal transitions that put most circuit-level simulators into difficulties, can also be addressed by using fuzzy-logic interfaces.

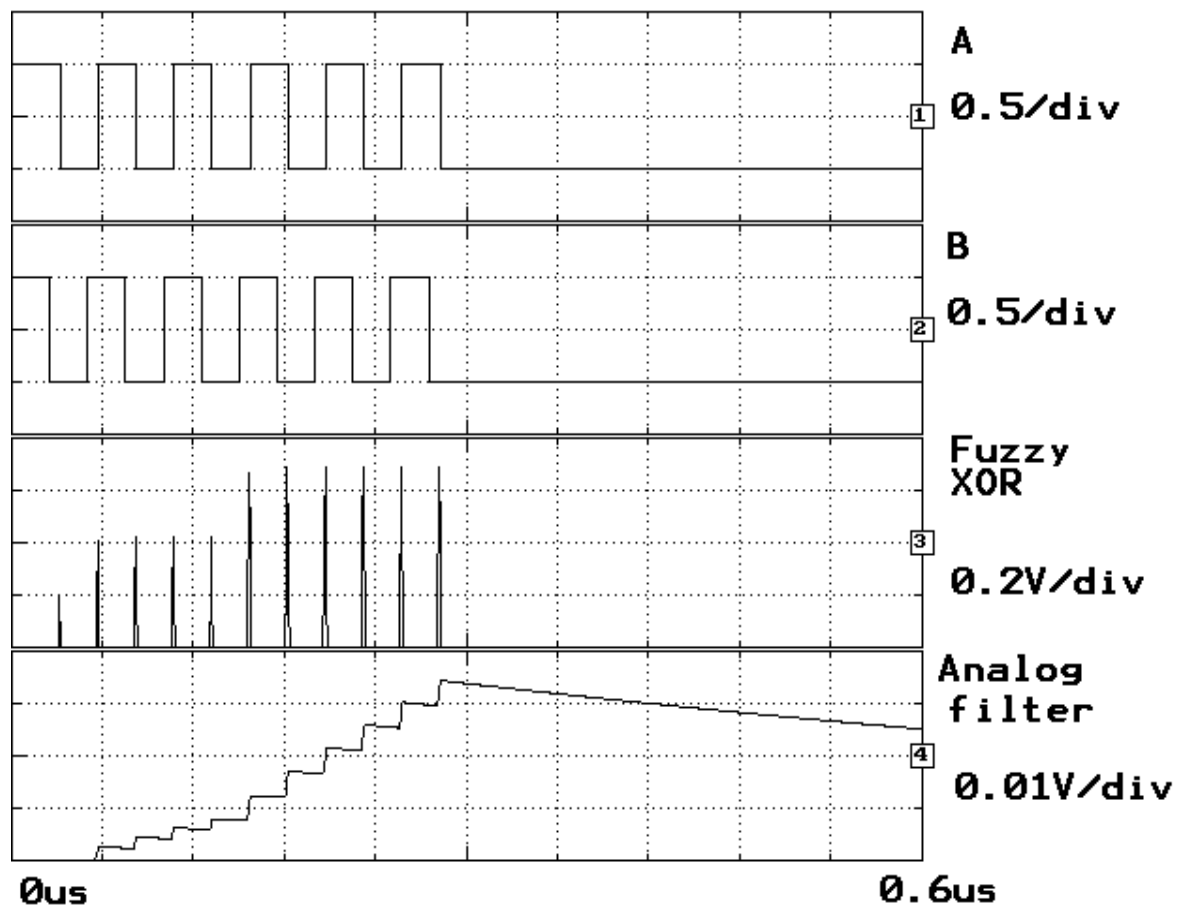

Figure 4. Spike propagation in a fuzzy-analogue interface.

5. Acknowledgment

The work was supported by SERC/DTI CLASS Project IED2/475/30/04 and carried out in collaboration with Philips Research Labs, Redhill and Number One Systems Ltd., St.Ives, UK.

6. References

- [1] Zadeh, L.A., "Fuzzy sets", *Info. Control*, no. 8, 1965, 338-353.
- [2] Lee R.C.T and C.L. Lang, "Some properties of fuzzy logic", *Info. Control*, no. 9, 1971, 413-431.
- [3] Marinos P.N. "Fuzzy logic and its application to switching systems", *IEEE Trans on Computers*, **C-18**, no. 4, 1969, 343-348.
- [4] Lee E.T., "Fuzzy logic and the resolution principle", *Journal of A.C.M.*, no 10. 1972, 109-119.
- [5] Nichols K.G. , A. D. Brown, M. Zwolinski and T. J. Kazmierski, "Modelling Non-Linear D-A and A-D Interfaces", *Research Journal 1995/96, Department of Electronics and Computer Science, Southampton University*, <http://www.ecs.soton.ac.uk/rj95/dag/kgn/report.htm>.
- [6] Zamfirescu A. and C. Ussery, "VHDL and fuzzy-logic if-then rules", *Proc. of Euro-VHDL'92, Hamburg, 1992*, 636-641.
- [7] Jimenez C.J., A. Barriga, D. Galan, S. Sanchez-Solano, "VHDL package for description of fuzzy-logic controllers", *Proc. of EURO-DAC'95, Brighton, 1995*, 528-533.
- [8] Genhog G., "A behavioral model of A/D converters using a mixed-mode simulator", *IEEE J. Solid-State Circuits*, **26**, no. 3, 1991.
- [9] Gielen G., E. Liu, A. Sangiovanni-Vincentelli and P. Gray, "Analog behavioral models for simulation and synthesis of mixed-signal systems", *Proc. of EDAC'92, Brussels, 1992*, 464-468.